



MAGNAVOX

2.1 CHANNEL SPEAKER SYSTEM

with Bluetooth® Wireless Technology

OWNER'S MANUAL

PLEASE READ BEFORE OPERATING THIS EQUIPMENT.



MODEL: MHT762





Size: 148.5(W) x 210(H)mm (A5)



IMPORTANT SAFETY INSTRUCTIONS

	CAUTION RISK OF ELECTRIC SHOCK DO NOT OPEN	
CAUTION: TO REDUCE THE RISK OF ELECTRIC SHOCK, DO NOT REMOVE COVER (OR BACK). NO USER-SERVICEABLE PARTS INSIDE. REFER SERVICING TO QUALIFIED SERVICE PERSONNEL.		

	The lightning flash with arrowhead symbol, within an equilateral triangle, is intended to alert user to the presence of uninsulated "dangerous voltage" within the product's enclosure, that may be of sufficient magnitude to constitute a risk of electric.
	The exclamation point within an equilateral triangle is intended to alert the user to the presence of important operating and maintenance (servicing) instruction in the literature accompanying the appliance.

FCC STATEMENT:

1. This device complies with Part 15 of the FCC Rules. Operation is subject to the following two conditions:
 - (1) This device may not cause harmful interference, and
 - (2) This device must accept any interference received, including interference that may cause undesired operation.
2. Changes or modifications not expressly approved by the party responsible for compliance could void the user's authority to operate the equipment.

NOTE: This equipment has been tested and found to comply with the limits for a Class B digital device, pursuant to Part 15 of the FCC Rules. These limits are designed to provide reasonable protection against harmful interference in a residential installation. This equipment generates, uses, and can radiate radio frequency energy and, if not installed and used in accordance with the instructions, may cause harmful interference to radio communications. However, there is no guarantee that interference will not occur in a particular installation. If this equipment does cause harmful interference to radio or television reception, which can be determined by turning the equipment off and on, the user is encouraged to try to correct the interference by one or more of the following measures:

- Reorient or relocate the receiving antenna.
- Increase the separation between the equipment and receiver.
- Connect the equipment into an outlet on a circuit different from that to which the receiver is connected.
- Consult the dealer or an experienced radio/TV technician for help.

FCC Radiation Exposure Statement:
This equipment complies with FCC radiation exposure limits set forth for an uncontrolled environment. This equipment should be installed and operated with minimum distance 20cm between the radiator & your body.

Before using the unit, be sure to read all operating instruction carefully, please note that these are general precautions and may not pertain to your

unit. For example, this unit may not have the capability to be connected to an outdoor antenna.

1. **Read these instructions**
All the safety and operating instructions should be read before the appliance is operated.
2. **Keep these instructions**
The safety and operating instructions should be kept for future reference.
3. **Heed all warnings**
All warnings on the appliance and in the operating instructions should be adhered to.
4. **Follow all instructions**
All operation and use instructions should be followed.
5. **Do not use this apparatus near water**
The appliance should not be used near water; for example, near a bath tub, washbowl, kitchen sink, laundry tub, in a wet basement, or near a swimming pool.
6. **Clean only with dry cloth**
The appliance should be cleaned only as recommended by the manufacturer.
7. **Do not block any ventilation openings. Install in accordance with the manufacturer's instructions.**
Slots and openings in the cabinet and in the back or bottom are provided for ventilation, to ensure reliable operation of the product and to protect it from overheating. These openings must not be blocked or covered. The openings should never be blocked by placing the product on a bed, sofa, rug, or similar surface. This product should never be placed near or over a radiator or heat source. This product should not be placed in a built-in installation, such as a bookcase or rack unless proper ventilation is provided or the manufacturer's instructions have been adhered to.
8. **Do not install near any heat sources such as radiators, heat registers, stoves, or other apparatus (including amplifiers) that produce heat.**
9. **Do not defeat the safety purpose of the polarized or grounding-type plug. A polarized plug has two blades with one wider than the other. A grounding type plug has two blades and a third grounding prong. The wide or the third prong are provided for your safety. If the provided plug does not fit into your outlet, consult an electrician for replacement of the obsolete outlet.**
10. **Product the power cord from being walked on or pinched particularly at plugs, convenience receptacles, and the point where they exit from the apparatus.**
11. **Only use attachments / accessories specified by the manufacturer.**

- 12. Use only with a cart, stand, tripod, bracket, or table specified by the manufacturer, or sold with the apparatus. When a cart is used, use caution when moving the cart/apparatus combination to avoid injury from tip-over.**



Portable Cart Warning

An appliance and cart combination should be moved with care. Quick stop, excessive force and uneven surfaces may cause the appliance and cart combination to overturn.

- 13. Unplug this apparatus during lightning storms or when unused for long periods of time.**

To protect your product from a lightning storm, or when it is left unattended and unused for long periods of time, unplug it from the wall outlet and disconnect the antenna or cable system. This will prevent damage to the product due to lightning and power-line surges.

- 14. Refer all servicing to qualified service personnel. Servicing is required when the apparatus has been damaged in any way, such as power-supply cord or plug is damaged, liquid has been spilled or objects have fallen into the apparatus, the apparatus has been exposed to rain or moisture, does not operate normally, or has been dropped.**

- 15. Power source**

This product should be operated only from the type of power source indicated on the marking label. If you are not sure of the type of power supply to your home, consult your appliance dealer or local power company. For products intended to operate from battery power, or other source, refer to the operation instructions.

- 16. Power lines**

An outside antenna system should not be located in the vicinity of overhead power lines or other electric light or power circuits, or where it can fall into such power lines or circuits. When installing an outside antenna system, extreme care should be taken to keep from touching such power lines or circuits as contact with them might be fatal.

- 17. Overloading**

Do not overload wall outlets and extension cords as this can result in a risk of fire or electric shock.

- 18. Object and liquid entry**

Never push objects of any kind into the product through openings as they may touch dangerous voltage points or short out parts that could result in fire or electric shock. Never spill or spray any type of liquid on the product.

- 19. Outdoor antenna grounding**

If an outside antenna is connected to the product, be sure the antenna system is grounded so as to provide some protection against voltage surges and built up static charges. Section 810 of the National Electric Code ANSI/ NFPA 70 provides information with respect to proper grounding of the mast and supporting structure, grounding of the lead-in wire to an antenna discharge product, size of grounding conductors, location of antenna-discharge product, connection to grounding electrodes and requirements for the grounding electrodes.

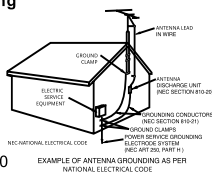

- 20. Service**

Do not attempt to service this product yourself as opening or removing covers may expose you to dangerous voltage or other hazards. Refer all servicing to qualified service personnel.

- 21. Replacement parts**

When replacement parts are required, be sure the service technician uses replacement parts specified by the manufacturer or those that have the same characteristics as the original parts. Unauthorized substitutions may result in fire or electric shock or other hazards.

- 22. Safety check**

Upon completion of any service or repairs to this product, ask the service technician to perform safety checks to determine that the product is in proper operating condition.

- 23. Damage requiring service**

- Unplug this product from the wall outlet and refer service to qualified service personnel under the following conditions.
- When the power-supply cord or plug is damaged.
- If liquid has been spilled or objects have fallen into the product.
- If the product has been exposed to rain or water.
- If the product does not operate normally by following the operating instructions. Adjust only those controls that are covered by the operating instructions, as an adjustment of other controls may result in damage and will require extensive work by a qualified technician to restore the product to its normal operation.
- If the product has been dropped or the cabinet has been damaged.
- When the product exhibits a distinct change in performance- this indicates a need for service.

- 24. Note to CATV system installer**

This reminder is provided to call the CATV system installer's attention to Article 820-40 of the NEC that provides guidelines for proper grounding and, in particular, specifies that the cable ground shall be connected to the grounding system of the building, as close to the point of cable entry as practical.

NOTE:

Refer all servicing to qualified service personnel. Servicing is required when the unit has been damaged in any way such as the following: the power-supply cord or plug has been damaged, liquid has been spilled into unit, the unit has been exposed to rain or moisture, the unit has been dropped or the unit does not operate normally.

- 25.** This equipment is a Class II or double insulated electrical appliance. It has been designed in such a way that it does not require a safety connection to electrical earth.

- 26. WARNING:** The mains plug is used as disconnect device, the disconnect device shall remain readily operable.

- 27. WARNING:** To reduce the risk of fire or electric shock, do not expose this apparatus to rain or moisture. The apparatus shall not be exposed to dripping or splashing and that objects filled with liquids, such as vases, shall not be placed on apparatus.

- 28.** Do not install this equipment in a confined or building-in space such as a book case or similar unit, and remain a well ventilation conditions at open site. The ventilation should not be impeded by covering the ventilation openings with items such as newspaper, table-cloths, curtains etc.

- 29.** No naked flame sources, such as lighted candles, should be placed on the apparatus. Attention should be drawn to environmental aspects of battery disposal. Use of the apparatus in moderate climates.

POWER SOURCE

Unwind the AC power cord on the rear of unit and extend it to its full length. Insert the AC plug of the cord into any convenient household outlet having AC 100–240V~ ; 50/60 Hz as the illustrated below:

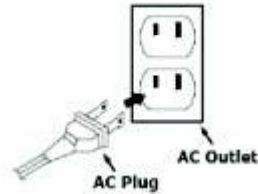

NOTES:

- This unit is equipped with a polarized AC plug which has one blade wider than the other. This is a safety feature to reduce the likelihood of electric shock.
- This polarized AC plug will only fit in a polarized AC outlet. If you find that you cannot insert this plug you're your outlet, you may have an obsolete non-polarized outlet. Please do not try to defeat this safety feature by using a non-polarized adaptor or by filling the wider blade to make it fit into your outlet.
- If this plug does not fit into your outlet, you should contact a qualified licensed electrician to replace your obsolete outlet.

BATTERIES INSTALLATION (Remote Control):

In first time use, slide the insulation film from the battery door and discard it as the illustrated follows:

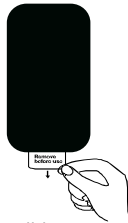

When the button cell is consumed, replace the button cell as below:

1. Push the tab on the battery tray and slide it out as the illustrated below:
2. Install a new CR 2025 button cell to the battery tray as the polarity markings on the rear of remote control cabinet.
3. Close the battery tray.

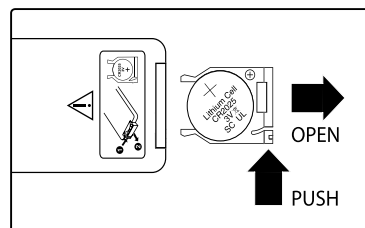

BATTERY PRECAUTIONS:

Follow these precautions when using a battery in this device:

1. Use only the size and type of battery specified.
2. Be sure to follow the correct polarity when installing the battery as indicated in the battery compartment. A reversed battery may cause damage to the device.
3. Do not mix different types of batteries together (e.g. Alkaline and Carbon-zinc) or old batteries with fresh ones.
4. If the batteries in the device are consumed or the device is not to be used for a long period of time, remove the batteries to prevent damage or injury from possible battery leakage.
5. Do not try to recharge the battery not intended to be recharged; it can overheat and rupture. (Follow battery manufacturer's instructions.)
6. Do not dispose of battery in fire. Battery may explode or leak.
7. Clean the battery contacts and also those of the device prior to battery installation.
8.  **Warning: DO NOT INGEST BATTERY, CHEMICAL BURN HAZARD**
This product contains a coin/button cell battery. If the coin/button cell battery is swallowed, it can cause severe internal burn in just 2 hours and can lead to death. Keep new and used batteries away from children. If the battery compartment does not close securely, stop using the product and keep it away from children. If you think batteries might have been swallowed or placed inside any part of the body, seek immediate medical attention.
9. **WARNING:** The batteries (battery pack or batteries installed) shall not be exposed to excessive heat such as sunshine, fire or the like.
10. **CAUTION:** Danger of explosion if battery is incorrectly replaced. Replace only with the same or equivalent type.

LOCATION OF CONTROLS:

Main unit

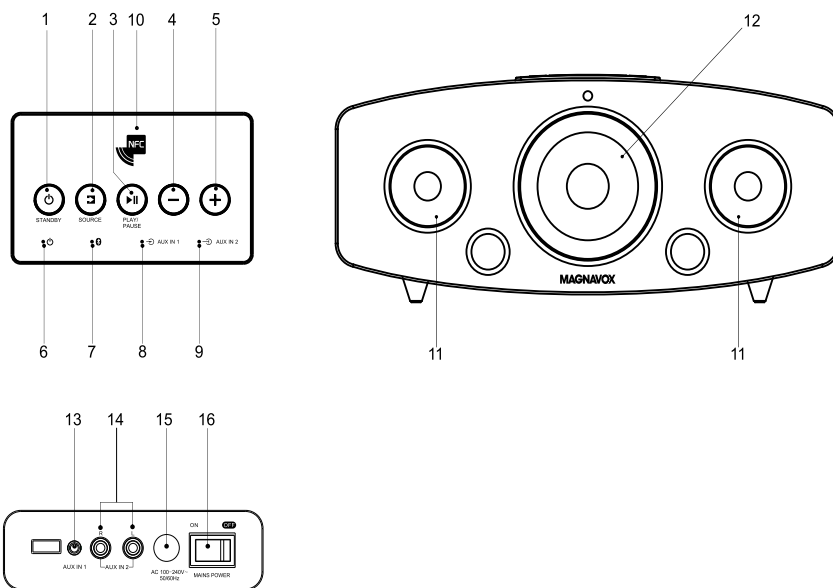

1. STANDBY Button
2. SOURCE Button
3. PLAY/PAUSE Button
4. Button
5. Button
6. Stand by Indicator
7. Bluetooth Indicator
8. AUX 1 (In) Indicator
9. AUX 2 (In) Indicator
10. NFC (Near Field Communication) Sensor
11. Loud Speakers
12. Super Woofer
13. AUX IN 1 Jack
14. AUX IN 2 Jacks
15. AC Power Cord
16. MAINS POWER ON/OFF Switch

LOCATION OF CONTROLS – REMOTE CONTROL

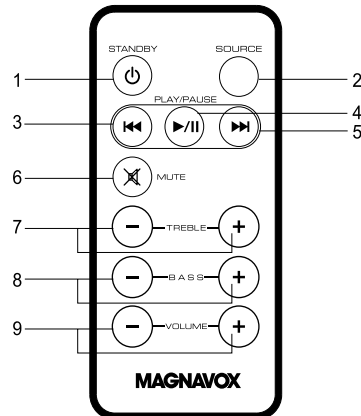

1. STANDBY Button
2. SOURCE Button
3. Button
4. PLAY/PAUSE Button
5. Button
6. MUTE Button
7. TREBLE +/- Buttons
8. BASS +/- Buttons
9. VOLUME +/- Buttons

EFFECTIVE DISTANCE OF REMOTE TRANSMITTER

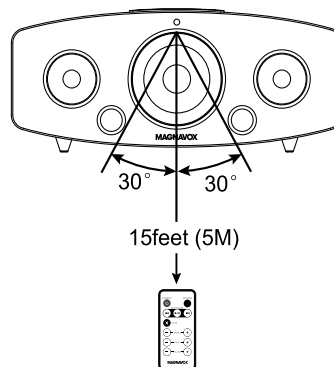

Remarks

1. When there is an obstacle between the unit and the transmitter, the transmitter may not operate.
2. When in direct sunlight, an incandescent lamp, fluorescent lamp or any other strong light shines on the remote sensor of the unit, the remote operation may be unstable.



OPERATIONS



GENERAL OPERATION:

1. Connect the unit to AC power as instructed.
2. Press the MAINS POWER ON/OFF Switch on the rear of unit to ON position to turn the unit to Standby Mode, the Red  (Stand by) Indicator on the top of unit will illuminate.
3. Press the  STANDBY Button on the top of unit or Remote Control to power on the unit from Standby Mode.
4. Press the  SOURCE Button on the top of unit or SOURCE Button on the Remote Control repeatedly to switch to BT (Bluetooth), AUX IN 1 or AUX IN 2 mode. The corresponding indicator will illuminate with your selection (see list below):

Indicators:

Playback Source/Mode:

 Bluetooth	BT (Bluetooth)
 AUX 1	AUX IN 1
 AUX 2	AUX IN 2

5. Press and hold the +/- Buttons on the top of unit or the +/- Buttons on the Remote Control to adjust volume level as desired.
6. Press the  MUTE Button to mute the sound, press again to turn it back.
7. Press the TREBLE +/- Buttons on the Remote Control to adjust the treble (high audio frequency) level as desired.
8. Press the BASS +/- Buttons on the Remote Control to adjust the bass (low audio frequency) level as desired.
9. When no longer in use, press the  STANDBY Button on the unit or Remote Control to place the unit in Standby Mode. The Red  (Stand by) Indicator will illuminate.

NOTE:

For energy saving, if unit is not going to be used for an extended period of time. Move the POWER ON/OFF Switch on the rear of unit to OFF position to power off the unit from Standby Mode.

BT (BLUETOOTH) PLAYBACK MODE:

BT PAIRING THROUGH NFC (Near Field Communication):

For first time use or re-pairing the unit to a new BT Device, pairing through the NFC as follows:

1. Make sure your external BT Device is equipped with NFC (Near Field Communication) and the function is set to it on.
2. Set the "BT Discovery Mode" (Make the device visible to all nearby Bluetooth devices) function of your external BT device to on.



NOTE: For details operation procedures of the NFC and BT Discovery Mode, please refer to the User's Manual of your BT Device.

3. Power on the unit and enter to BT playback mode as instructed earlier. The  (Bluetooth) Indicator on the top of unit will illuminate and blink.
4. Wake up your external BT Device then place it on the NFC Sensor (the NFC logo on the top of unit).

NOTES: Make sure the NFC Sensor of your BT Device is placed on the top of the NFC Sensor of the unit closely and correctly. Otherwise, the unit may not detect your BT Device. If you don't know where the location of NFC Sensor your BT Device, please check the User's Manual of it or consult the retailer where you bought the BT Device.

5. A few seconds later, a small window for pairing request will pop up on the external BT Device's display. Then start pairing following the on screen instructions from the external BT Device.



NOTE: Our model number "MHT762" may appear on the BT Device's display.

6. After paired, pull away the BT Device from the unit then play the music in the paired external BT Device as usual.
7. During playback:
 - Press the  Button on the unit or Remote Control to pause: press again to resume normal playback.
 - Press and hold the +/- Buttons on the unit or press the VOLUME +/- Buttons on the Remote Control to adjust volume level as desired.
 - Press and release the +/- Buttons on the unit or the  Buttons on the Remote Control repeatedly to skip tracks.

IMPORTANT:





If your BT Device can NOT be paired to the unit through the NFC, it maybe because the NFC system on your external BT device is not compatible with our unit. In this case, connect your device to the unit through normal BT (Bluetooth) connection on the page 11.

Normal operation after paired:

1. Power on the unit and enter to BT playback mode as instructed earlier. The  Bluetooth Indicator on the top of unit will illuminate and blink.
2. Wake up your external BT Device then place it on the NFC Sensor of the unit.
3. Wait a few seconds until the unit is automatically paired to the external BT Device. The  (Bluetooth) Indicator will stop blinking.
4. Pull away the BT Device from the unit then play the music on the paired BT Device as usual.

BT PAIRING MANUALLY:



If yours BT Device without NFC (Near Field Communication) function,(or the NFC system of the external BT Device not match)pair it to the unit manually before first time use (or re-pairing to a new BT Device) as below:

1. Power on the unit and enter to BT playback mode as instructed earlier. The  (Bluetooth) Indicator on the top of unit will illuminate and blink.
2. Power on the external BT Device and enter to BT searching mode. Start pairing following the on screen instructions from the external BT Device. After paired, the  (Bluetooth) Indicator will stop blinking.
3. Plays the music in the paired BT Device as usual.
4. During playback:
 - Press the  Button on the unit or Remote Control to pause: press again to resume normal playback
 - Press and hold the +/- Buttons on the unit or press the VOLUME +/- Buttons on the Remote Control to adjust volume level as desire.
 - Press and release the +/- Buttons on the unit or  /  Buttons on the Remote Control repeatedly to skip tracks.

NOTES:

- When the external BT Device searched the unit, our model number "MHT762" will appear on the display of external BT Device.
- Pairing code "0000" or "1234" may need to enter.

Normal operation after paired:

1. Power on the unit and enter to BT playback mode as instructed earlier. The  (Bluetooth) Indicator on the top of unit will illuminate and blink.
2. Wait a few seconds until the unit auto paired to the external BT Device. The  (Bluetooth) Indicator will stop blinking.
3. Plays the music in the paired BT Device as usual.

AUX IN 1 PLAYBACK:

1. Insert one of the plug from the supplied Audio Connection Cable (with 3.5mm stereo mini plugs) to the Phones Jack; Line Out Jack or AUX Out Jack on the external Audio Player such like the iPhones; iPad; iPod; MP3 Player; Discman ... etc.
2. Insert the other plug to the AUX IN 1 Jack on the rear of unit as the illustrate on right.
3. Power on the unit and enter to AUX IN 1 playback mode as instructed earlier. The  AUX IN 1 Indicator on the top of unit will illuminate.
4. Plays the music on the connected external Audio Player as usual. (Make sure the volume level of the external Audio Player is in high level. Otherwise, sound from this unit may weak).

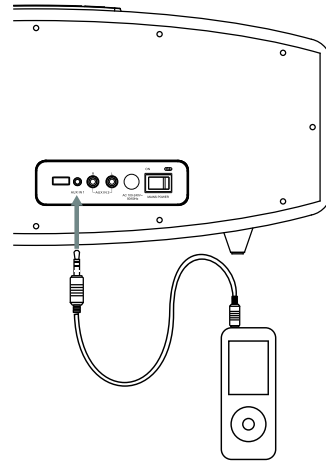

AUX IN 2 PLAYBACK:

1. Insert one end of the RCA connection cable (not supplied) to the Audio Out Jacks (RCA Type) on external Audio/Video Player such like TV;DVD Player; VCR ... etc.
2. Insert the other end to the AUX 2 Jacks on the rear of unit as the illustrate on right.
3. Power on the unit and enter to AUX IN 2 playback mode as instructed earlier. The  AUX IN 2 Indicator on the top of unit will illuminate.
4. Plays the music/video on the connected external Audio/Video Player as usual. (Make sure the volume level of the external Audio/Video Player is in high level. Otherwise, sound from this unit may weak).

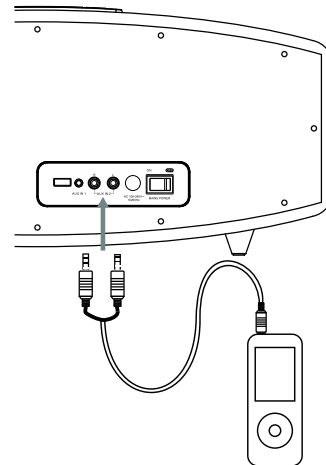

TROUBLESHOOTING GUIDE

SYMPTOM	POSSIBLE CAUSE	POSSIBLE SOLUTION
No power	AC Power cord had not connected to wall outlet	Connect the AC Power Cord to wall outlet
	The MAINS POWER ON/OFF Switch is in OFF position	Press the MAINS POWER ON/OFF Switch on the rear of unit to ON position to power on the unit
	The unit in standby mode	Press the  STANDBY Button to power on the unit from Standby Mode
No sound or sound weak	Volume of the unit was set to minimum position	Increase the volume by press and hold the + Button on the unit or press the VOLUME + Button on the Remote Control
	Volume level of paired/connected device is in low level	Rise the volume level of the paired/connected device
Sound distortion	Volume level too high	Reduce the volume level by press and hold the - Button on the unit or press the VOLUME - Button on the Remote Control
	Volume level of the connected/paired device too high	Reduce the volume level of the connected/paired device
BT not functioning	The external BT Device had NOT paired to the unit	Pair the external BT Device to the unit as page 9
	The external BT device too far from the unit	Place the external BT device close to the unit
NFC not functioning	The NFC system of yours BT Device may not match the unit	Try the others NFC device
	Yours device had not place on the NFC Sensor closely and correctly	Check and make sure where is the location of the NFC sensor in your device then place it on the NFC logo on the top of unit

SPECIFICATIONS:

Power Source:..... AC 100-240V~;50/60Hz

Power Consumption:.....130 W (Max.)

Audio Power:

Loud Speakers:.....2 x 20 Watts (RMS)

Woofer:.....60 Watts (RMS)

Total:.....100 Watts (RMS)

Impedance of the speakers:

Loud Speakers:.....2 x 25 W; 6 ohm

Woofer:80 W; 6 ohm

BT Version:.....V4.1

BT Operation Distance:.....≥32 Feet in opera area

NFC Version:.....NTAG203F NXP

PACKAGE INCLUDES:

1 x User's Manual

1 x Audio Connection Cables with 3.5mm Plugs

1 x Remote Control (Uses 1 x CR2025 Button Cell, included)

**SPECIFICATIONS AND ACCESSORIES ARE SUBJECT
TO CHANGE WITHOUT NOTICE**



LIMITED WARRANTY

Craig Electronics warrants this product to be free from manufacturing defects in material and workmanship under normal use for a period of 180 days from date of purchase. If service is required, please return the product to the store where it was purchased for exchange; or, pack the unit in the original packing material with all accessories if applicable, a copy of your sales receipt and a Cashier's check or Money Order for \$20 (to cover shipping and handling costs) payable to Craig Electronics Inc. For consumers in Canada, please make sure that the cashier check or money order is redeemable through a U.S. bank. Ship your product freight pre-paid. Your unit will be repaired, replaced or if the unit can not be repaired or replaced, a refund will be forwarded to you within four weeks of receipt of your unit. Please ship your unit to:

Craig Electronics Inc.
1160 NW 163 Drive
Miami, FL 33169

This warranty is void if the product has been: a) Used in a commercial application or rental. b) Damaged through misuse, negligence, or abuse. c) Modified or repaired by anyone other than an authorized Craig service center. d) Damaged because it is improperly connected to any other equipment.

Note: This warranty does not cover: a) Ordinary adjustments as outlined in the Owner's Manual which can be performed by the customer. b) Damage to equipment not properly connected to the product. c) Any cost incurred in shipping the product for repair. d) Damage to the product not used in the USA.

This warranty is not transferable and only applies to the original purchase. Any implied warranties, including the warranty of merchantability, are limited in duration to the period of this expressed warranty and no warranty whether expressed or implied shall apply to the product thereafter.

Under no circumstance shall Craig be liable for any loss or consequential damage arising out of the use of this product. This warranty gives specific legal rights. However, you may have other rights which may vary from state to state. Some states do not allow limitations on implied warranties or exclusion of consequential damage. Therefore, these restrictions may not apply to you.

This product has been manufactured by and is sold under the responsibility of Craig Electronics Inc, and Craig Electronics Inc is the warrantor in relation to this product. MAGNAVOX and SMART. VERY SMART are registered trademarks of Koninklijke Philips N.V. and are used under license from Koninklijke Philips N.V.

To Obtain Service on your Product
email: service@craigelectronics.com

Printed in China

MHT762_WC_E0HY1_B0WU



